



VENTUS

Platinum

2024/2025



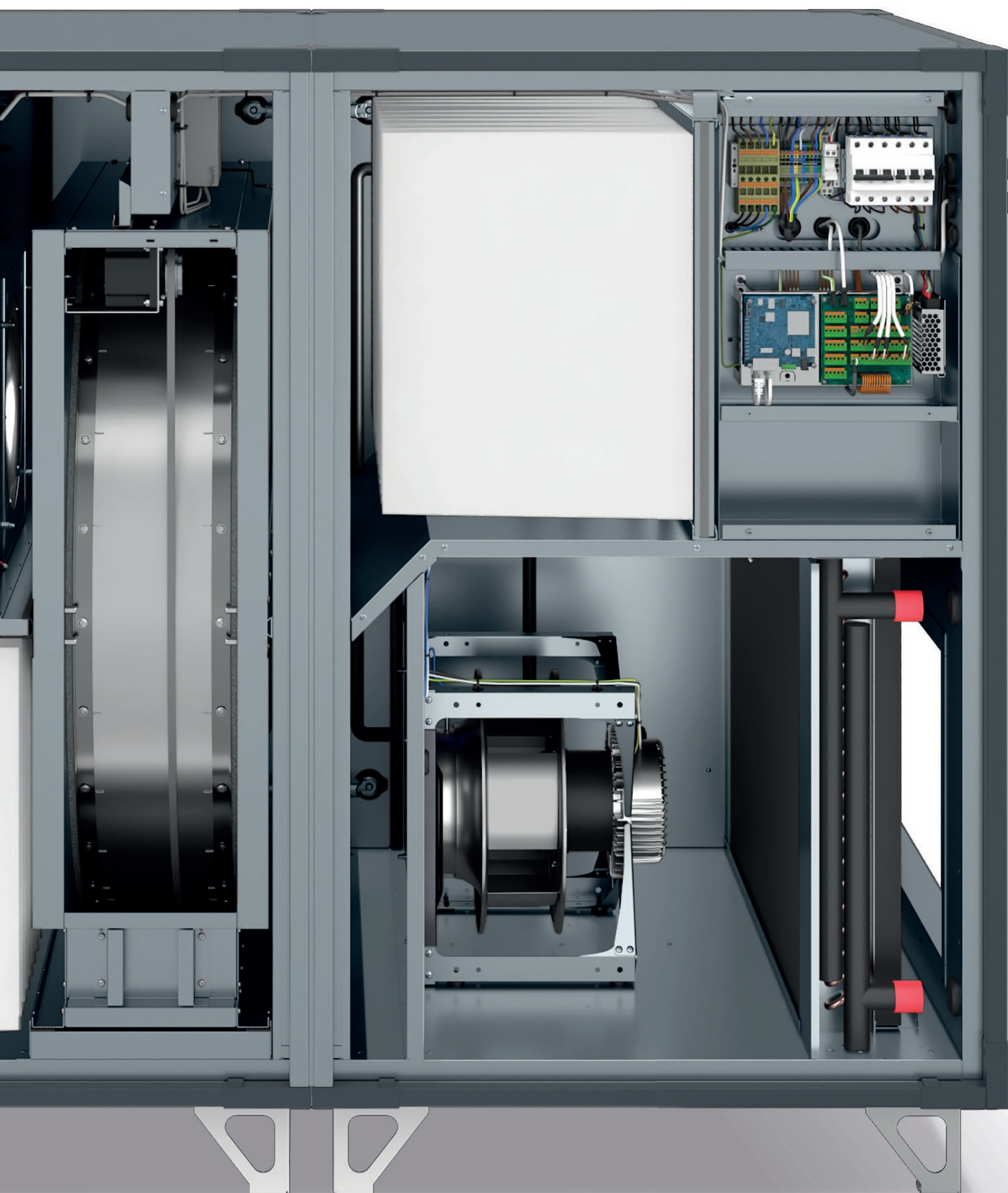

QUALITY:

- » Eurovent-certified casing: T2, TB2, L1, D1, F9

COMPACT CASING:

- » Casing material - Magnelis® (magnesium-zinc coating)
- » Mineral wool insulation - panel thickness: 50 mm
- » Mechanically poured gasket

HIGH EFFICIENCY:

- » Rotary heat exchanger: condensing or sorption
- » HEX counterflow heat exchanger: aluminium
- » Highly efficient fan sets with electronically commutated (EC) motors

COMPACT SIZE:

- » Ability to move the unit through a 900 mm door
- » Air handling unit base configuration: heat recovery, fan sets, filters, heater (optional)
- » Number of sections:
 - Sizes VVSA11-22 RRG and HEX - one section
 - Sizes VVSA29-56 RRG - two sections
 - Sizes VVSA29-40 HEX - three sections

EASY TO MAINTAIN AND CLEAN:

- » Access to the unit from both sides
- » Easy access for cleaning fan sets and heat exchangers

CONTROLS:

- » Multifunctional controls integrated with the unit
 - configured and ready to operate (Plug&Play)
- » mHMI application available as standard on the unit
- » Possibility of remote management when connected to the VTS cloud

CERTIFICATES

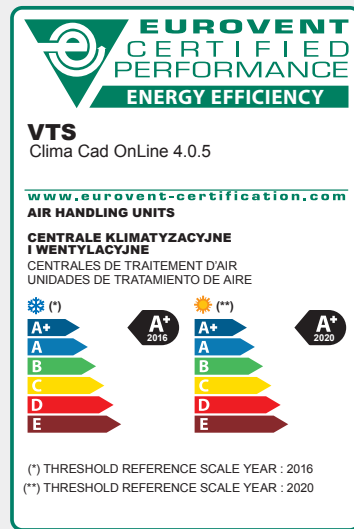

Casing parameters compliant with EN1886 standard	Class
Thermal bridging	TB2
Thermal transmittance	T2
Casing air tightness	L1
Mechanical properties	D1
Filter tightness	F9

VENTUS Platinum AHUs are compliant with the requirements of the **Ecodesign 1253/2014** directive.

VENTUS Platinum AHUs are manufactured in accordance with:

- » **ISO 9001 certificate** - guarantees full repeatability of production of the AHUs
- » **ISO 14001 certificate** - confirms effective environmental management

VENTUS Platinum AHUs are CE certified:

- » a declaration of conformity with European standards concerning the safety of equipment operation and requirements for electromagnetic compatibility



PANELS

- » Panels made of mineral wool, double-sided coated with metal sheet with zinc-magnesium coating - Magnelis®
- » Corrosion class: C5
- » Panel thickness: 50 mm
- » Thermal insulation: mineral wool



POURED GASKET

- » High tightness of inspection panels achieved through the use of a poured gasket
- » Continuity of the gasket along the entire length
- » Microbiological neutrality



DOOR HANDLES

- » Easy access to panel components
- » Adjustable roller pressure ensures that the panels remain sealed during the life of the air handling unit



BENEFITS of Magnelis®:

- » **Exceptional corrosion resistance** - magnesium in the coating forms a stable protective layer on the steel surface, allowing long-term protection in harsh environments
- » Self-repairing properties - the presence of magnesium supports coating regeneration
- » Environmentally friendly - reduced zinc content

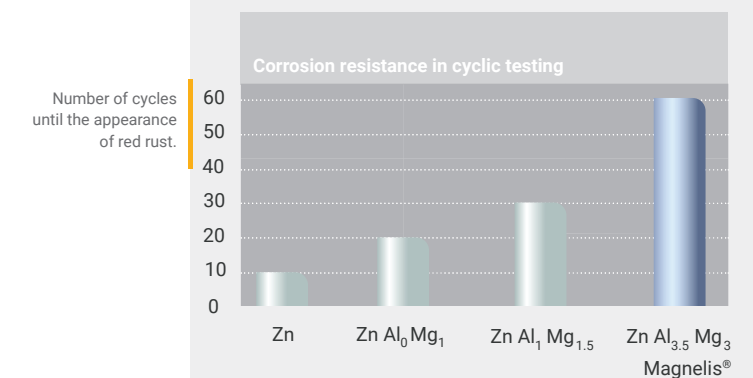

10 µm of coating submitted for an alternated cycling of 8 hours fog cycle (5% NaCl) / dry cycle / humidity cycle. Source: ArcelorMittal Global R&D

AIR HANDLING UNITS WITH ROTARY HEAT EXCHANGER

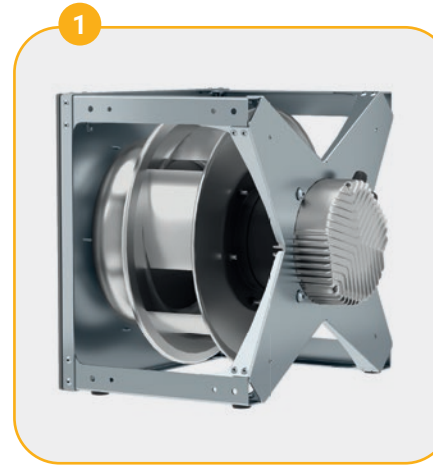
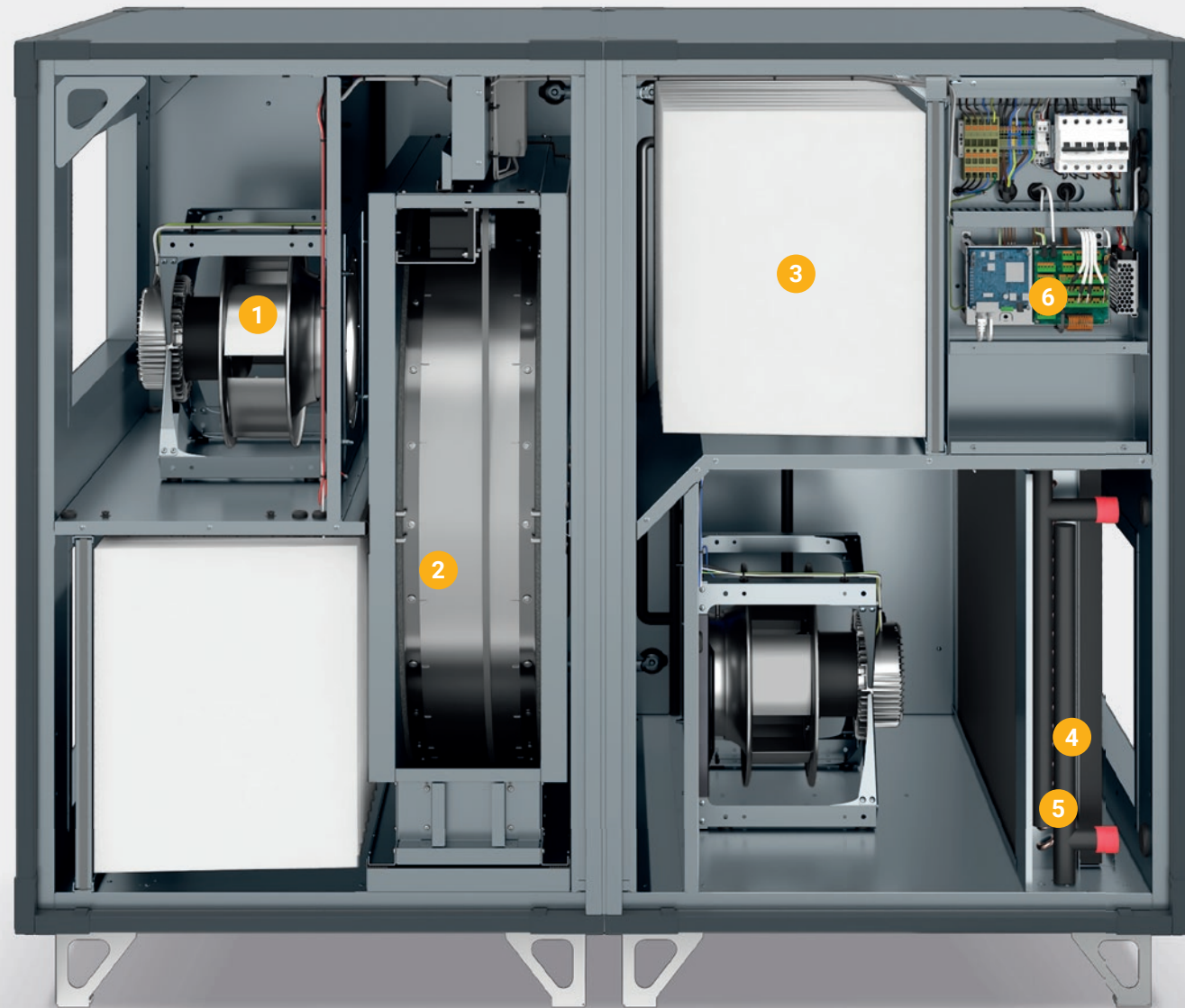

FAN SET

- » Efficient, quiet fan with high-efficiency EC motor of IE4 class

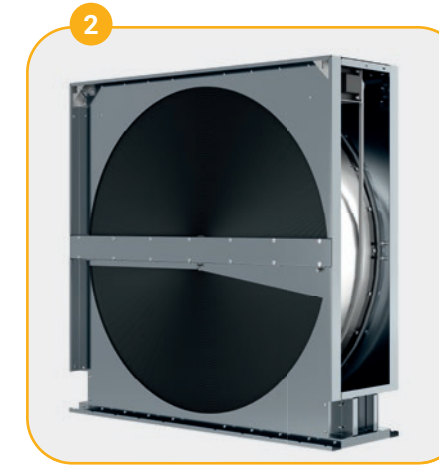

ENERGY RECOVERY

- » Rotary heat exchanger: condensation or sorption
- » Up to 90% heat recovery efficiency
- » Adjustable cleaning sector angle



FILTERS

- » Filter type - pocket filters
- » Filtration class: ePM10 50% - ePM1 80%
- » Gasket on the frame ensures high level of tightness

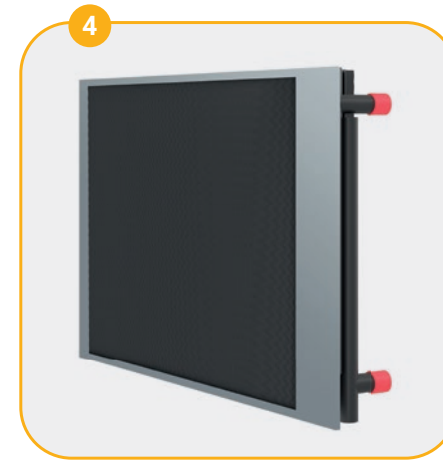

WATER HEATER (BUILT-IN)

- » Number of rows - 1 or 2
- » Easy to clean exchanger
- » Easy to service



ELECTRIC HEATER (BUILT-IN)

- » Heater power from 3 to 21 kW (depending on unit size)
- » Dual protection level in the power circuit
- » Smooth adjustment across the full power range
- » Ease of maintenance

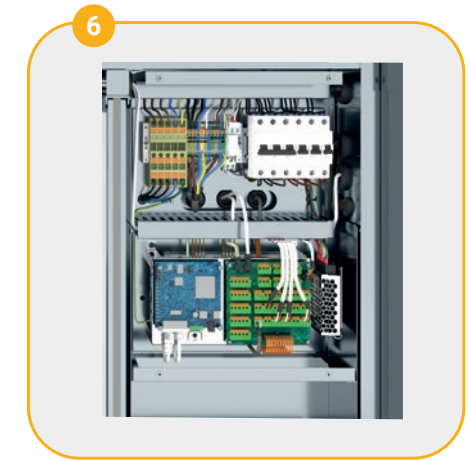

CONTROLS:

- » Multifunctional controls integrated with the unit - configured and ready to operate (Plug&Play)
- » Ability to connect service devices without opening the unit
- » Remote servicing capability via Ethernet, Wi-Fi, Bluetooth, GSM

AIR HANDLING UNITS WITH COUNTERFLOW HEAT EXCHANGER

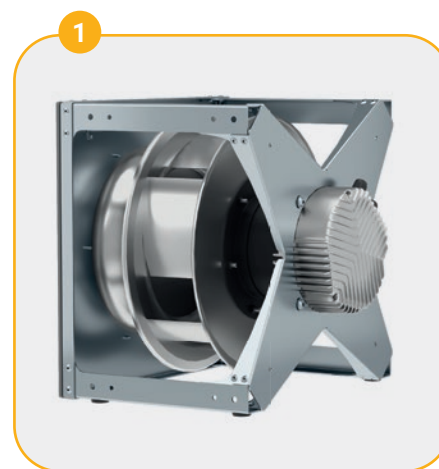
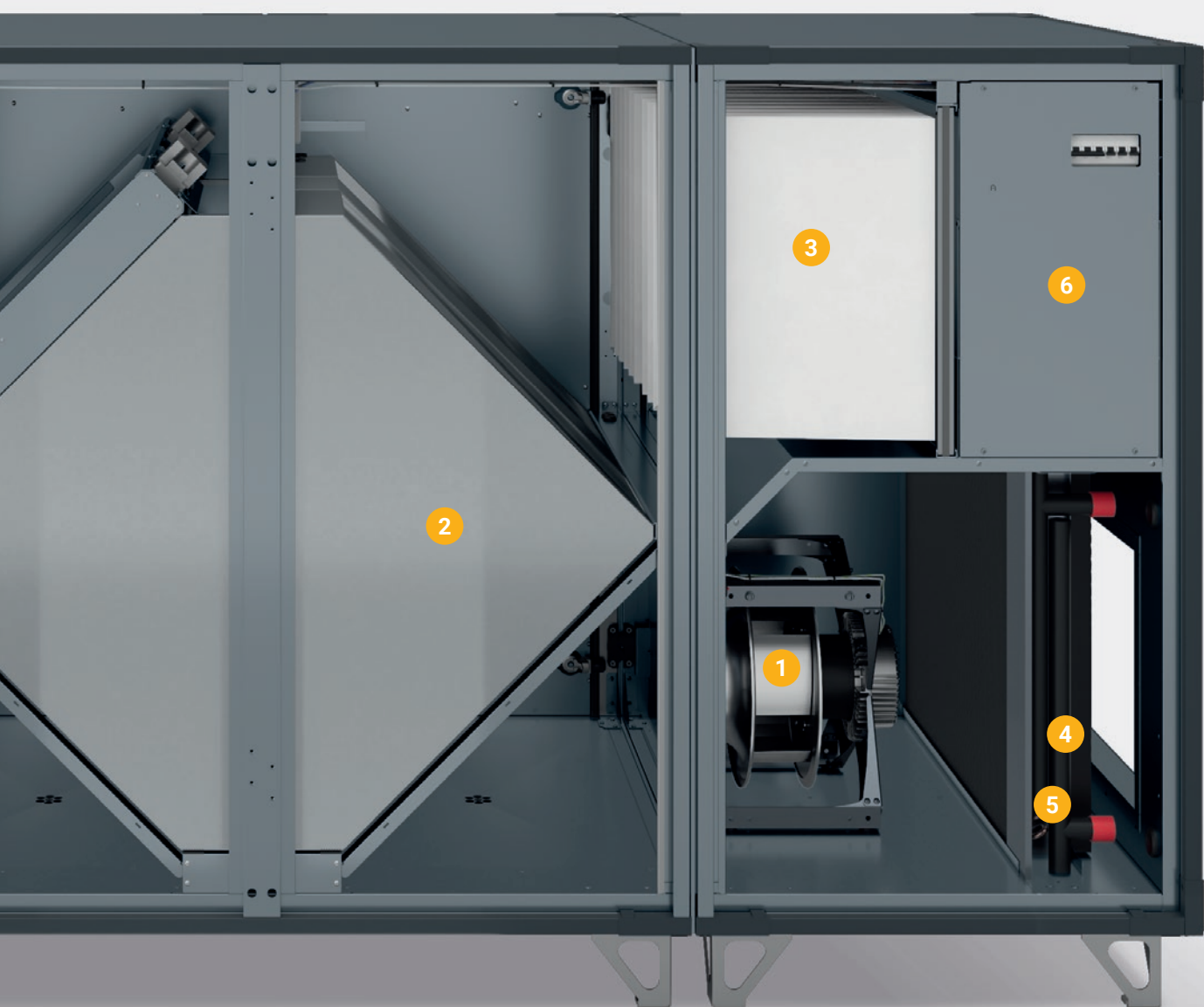

FAN SET

- » Efficient, silent fan with high efficiency EC motor of IE4 class



ENERGY RECOVERY

- » High efficiency hexagonal counterflow heat exchanger with bypass
- » Material - aluminium
- » Up to 90% efficiency
- » Operating temperature range: -40°C to +90°C



FILTERS

- » Filter type - pocket
- » Degree of filtration: ePM10 50% - ePM1 80%
- » Gasket on the frame ensures high level of tightness

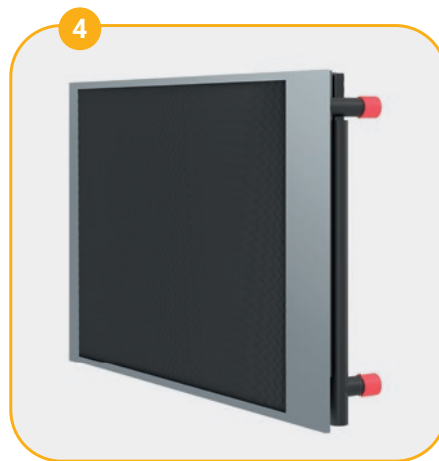

WATER HEATER (BUILT-IN)

- » Number of rows - 1 or 2
- » Easy to clean exchanger
- » Easy to service



ELECTRIC HEATER (BUILT-IN)

- » Heater power from 3 to 21 kW (depending on unit size)
- » Dual protection level in the power circuit
- » Smooth adjustment across the full power range
- » Ease of maintenance

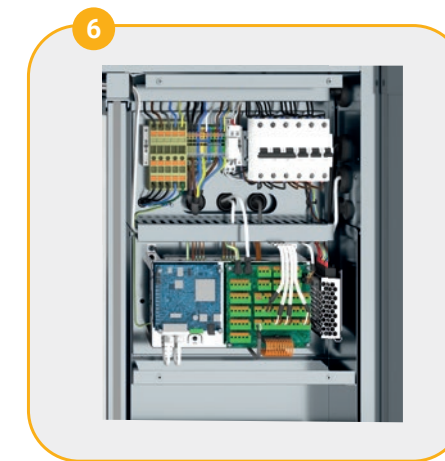

CONTROLS

- » Multifunctional controls integrated with the unit - configured and ready to operate (Plug&Play)
- » Ability to connect service devices without opening the unit
- » Remote servicing capability via Ethernet, Wi-Fi, Bluetooth, GSM

AIR HANDLING UNITS WITH ROTARY HEAT EXCHANGER

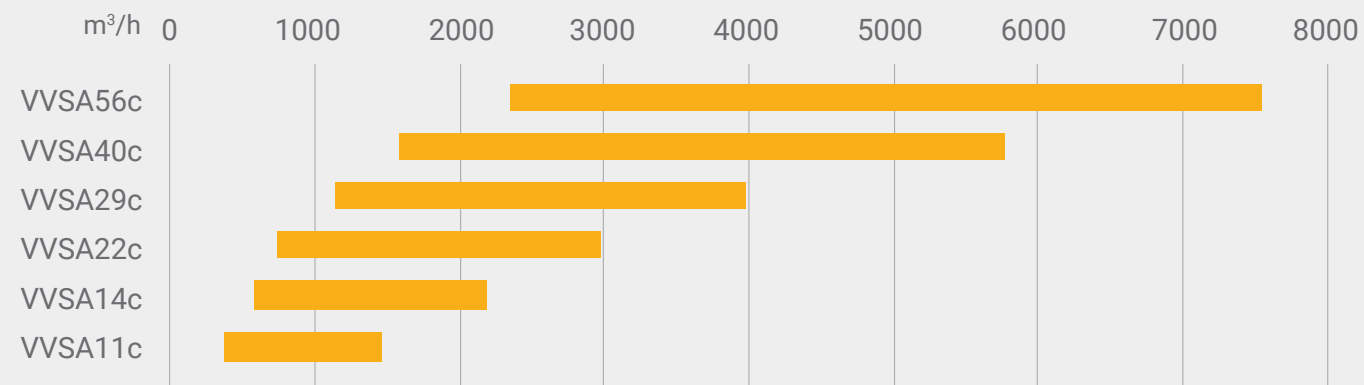

Size	Min. air flow	Max. air flow	Height *	Width	Length	Connection diameter	Connection height	Connection width	Frame height
	m³/h	m³/h							
VVSA11c	390	1461	962	750	1385	315	-	-	120
VVSA14c	590	2184	1062	865	1490	400	-	-	120
VVSA22c	740	2972	1175	947	1605	-	400	500	120
VVSA29c	1150	3990	1330	1124	1752	-	400	700	120
VVSA40c	1590	5764	1478	1284	1752	-	400	800	120
VVSA56c	2350	7538	1718	1514	1752	-	500	1000	120

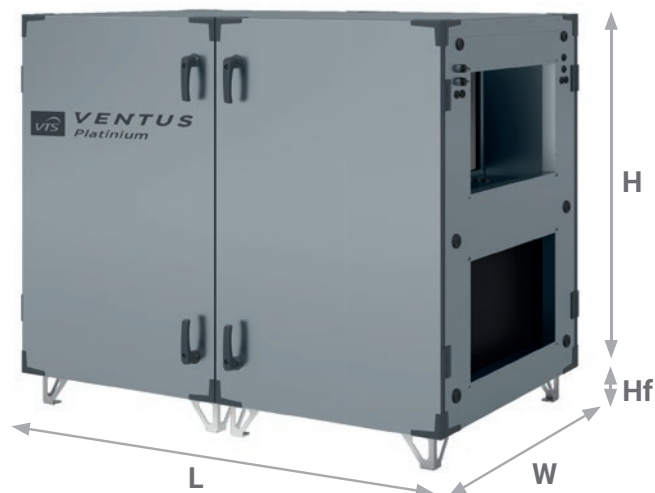

* The height of the unit does not include the height of the frame

AIR HANDLING UNITS WITH COUNTERFLOW HEAT EXCHANGER

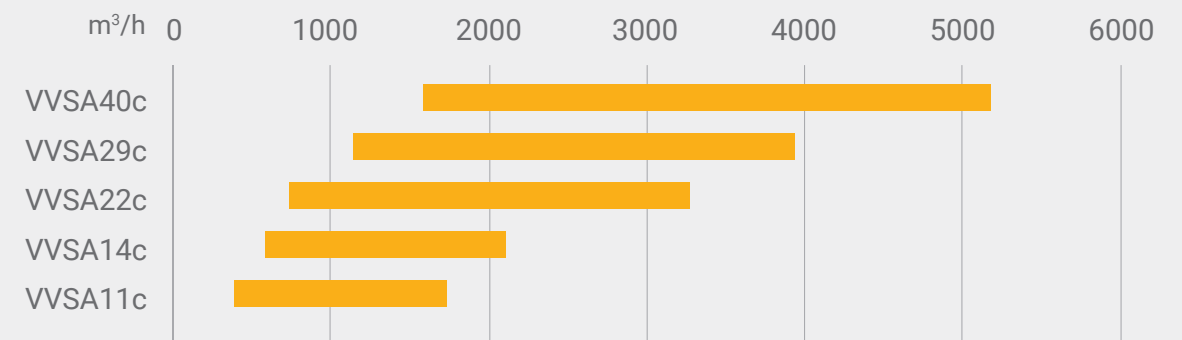
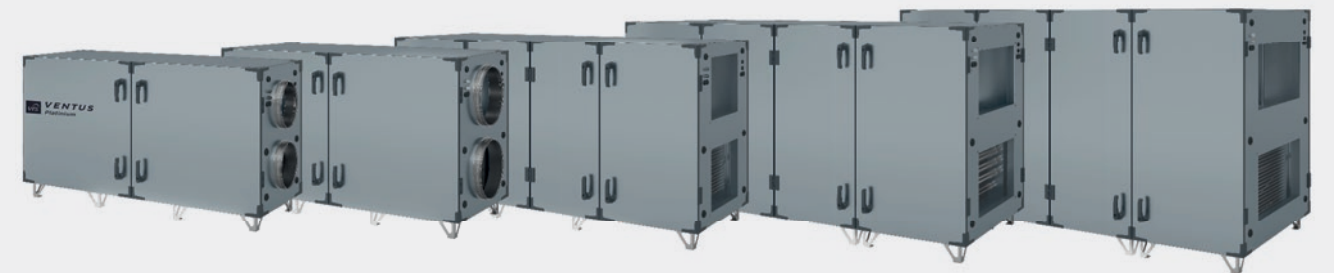

Size	Min. air flow	Max. air flow	Height *	Width	Length	Connection diameter	Connection height	Connection width	Frame height
	m³/h	m³/h							
VVSA11c	390	1737	962	750	1385	315	-	-	120
VVSA14c	590	2113	1062	865	1490	400	-	-	120
VVSA22c	740	3269	1175	947	1605	-	400	500	120
VVSA29c	1150	3938	1330	1124	1752	-	400	700	120
VVSA40c	1590	5178	1478	1284	1752	-	400	800	120

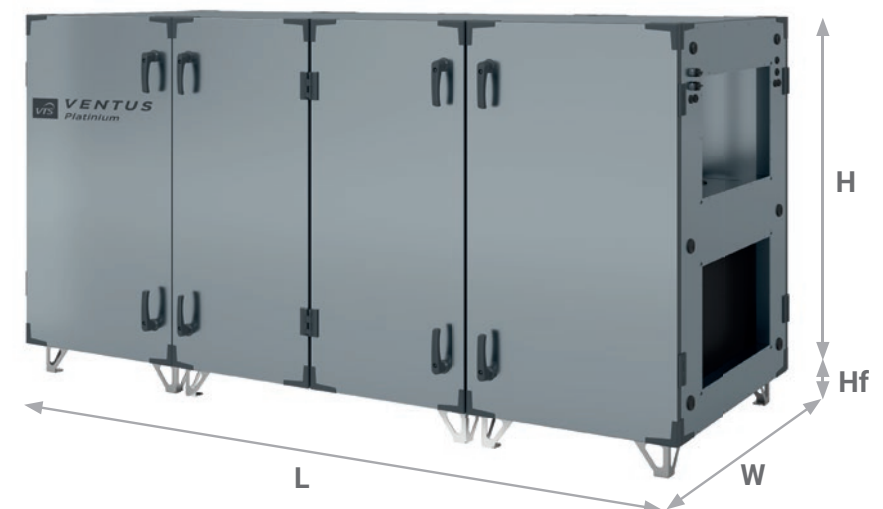

* The height of the unit does not include the height of the frame

ADDITIONAL AIR HANDLING FUNCTIONS

» UNITS WITH ROTARY AND COUNTERFLOW HEAT EXCHANGER



ADDITIONAL PROTECTION AGAINST EXTERNAL CONDITIONS:

- » roof over base unit and extensions
- » cover on air dampers actuator

Available additional features: duct silencer, freon cooler, water cooler.

			VVSA11c	VVSA14c	VVSA22c	VVSA29c	VVSA40c	VVSA56c
Silencer	Length	mm	300/1000	300/1000	1065	1065	1065	1065
	External width	mm	630	750	794	910	1070	1300
Freon cooler	External height	mm	410	460	584	662	736	856
	Length	mm	540	540	771	771	771	771
Water cooler	External width	mm	630	750	794	910	1070	1300
	Outside height	mm	410	460	584	662	736	856
	Length	mm	540	540	718	718	718	718

EQUIPMENT SERVICING

Heat recovery system accessible from both sides for servicing and cleaning.



Connecting service equipment without opening the unit.



Easy disassembly of fan sets assemblies for servicing and inspection purposes.

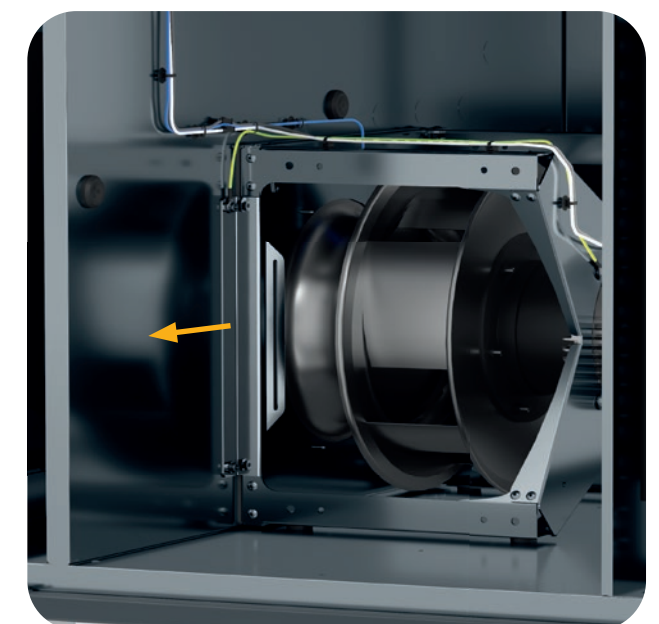

ADDITIONAL PROTECTION AGAINST EXTERNAL CONDITIONS

- » Additional protection of the connection point to the main
- » Additional casing for damper actuators



3 EXTERNAL COMMUNICATION PORTS

- » Connecting to the controller without opening the unit



CONTROLS

- » Positioned in the exhaust air path, which prevents condensation on controls components
- » Multifunctional controls integrated with the unit - configured and ready to operate (Plug&Play)
- » Ability to connect service devices without opening the unit
- » Remote servicing capability via Ethernet, Wi-Fi, Bluetooth, GSM



DEDICATED AIR-HANDLING MEASUREMENT BOARD

- » Optimised connections inside the air handling unit
- » Active filter contamination measurement
- » Continuous air volume (CAV) control
- » Exhaust air temperature and humidity measurement

VTS provides control automation with a factory-implemented application enabling remote monitoring and management of the air handling unit's operating parameters in real time using a web browser run on any mobile device.

VENTUS MANAGEMENT SYSTEM:

- » Display of visualizations on various devices – from computers to mobile devices
- » Monitoring and management of a larger number of devices from the open visualisation of a single control panel
- » Easy and intuitive change of the device mode via a central button
- » Tools to support easy and quick setup of the device's optimal operating schedule



VTS Group provides the mHMI application, which enables commissioning, monitoring of operation and management of parameters of **VENTUS** compact and modular air handling units. The application can be downloaded from the Google Play and AppStore.



The app connects to the air handling unit using GSM technology (VTS Cloud) or Bluetooth, depending on the user's preference.



Meeting the expectations of its customers, **VTS Group** has created its own cloud solution called **VTS Cloud**. It is dedicated to compact and modular units with **VTS Group** automation

The most important benefits from using VTS Cloud are:

- » **Energy monitoring and optimisation**
VENTUS AHUs connected to VTS Cloud enable continuous monitoring of energy consumption, allowing trends and areas that can be optimised for energy savings to be identified.
- » **Intelligent control**
With VTS Cloud, the control of VENTUS air handling units can be made more intelligent and adapted to changing conditions. Algorithms process the operating data of the units, allowing them to be adjusted for optimum comfort and efficiency.
- » **Diagnostics and maintenance**
VTS Cloud allows remote diagnostics and monitoring of the health of the air handling unit, enabling a rapid response to failure. Users also receive direct information about the need to replace consumable elements, such as filters, with a redirection to the VTS Group online store.
- » **Cooperation with BMS**
VTS Cloud-supported devices enable the connection to be configured and thus simultaneously connected to the cloud without losing the connection of the control panel to the local BMS. This allows both local use of the control panel data and all remotely offered VTS Cloud services.

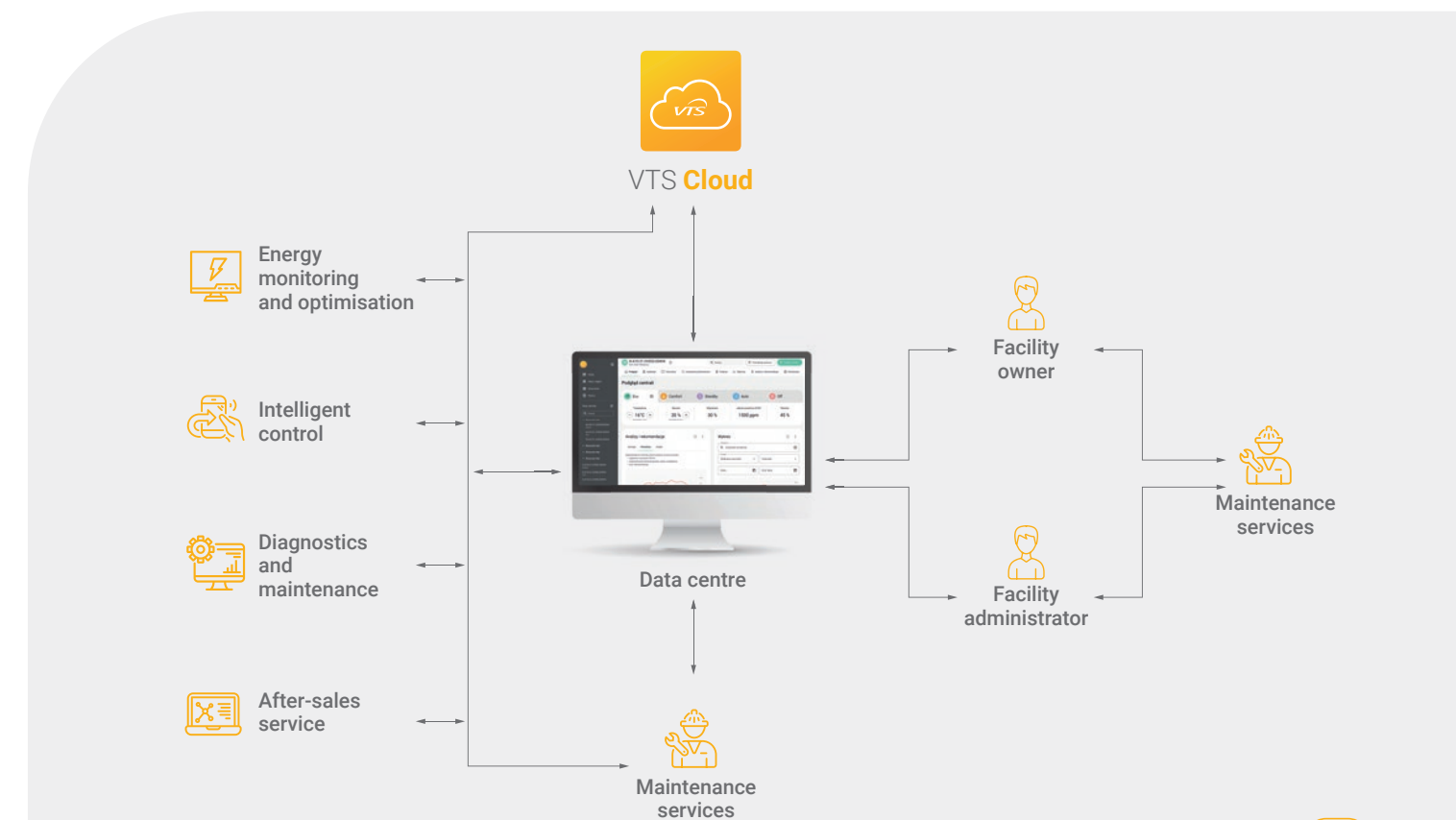



VTS Group S.A.

20, rue de l'Industrie
L-8399 Windhof, Luxembourg
Phone: +352 20 60 22 41
Email: contact@vtsgroup.lu

www.vtsgroup.com

The information provided in this publication is subject to continuous improvement and may change.
VTS Group reserves the right to make design and specification changes to the offered units without prior notice.